

8-DIMM Add-In Card (CXA-8F2W)

For the CXL[®] Standard

SMART's CXA-8F2W is an 8-DIMM AIC utilizing the CXL standard. It's a Type 3 PCIe Gen5 Add-In Card (AIC) consisting of eight DDR5 RDIMMs mounted on a Full Height, Half Length PCIe form factor module. It uses two x16 CXL controllers to implement two x8 CXL ports capable of a total bandwidth of 64GB/s.

Each RDIMM socket supports up to 512GB RDIMMs for a maximum memory capacity of 4TB. The CXL Controllers implement "Reliability, Availability, and Serviceability" (RAS) features, advanced analytics, as well as enhanced security features with in-band or side band (SMBus) monitoring capability.

SMART develops Type 3 (CXL.mem) memory products utilizing the CXL standard to address the industry's need for more memory per processor core. The CXL interconnect specification allows for a significant expansion of memory form factor options in PCIe or EDSFF form factors.

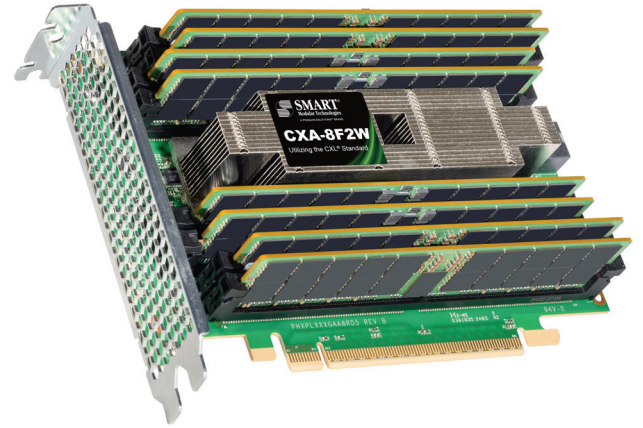

Key Features

- Host Interface
 - CXL 2.0
 - Two x16 ASICs
 - Up to 64GB/s throughput
- Memory Interface
 - 8 x 512GB DDR5 RDIMMs (4TB max)
 - Each of the two controllers supports two Channels up to DDR5-4800
 - Each Channel supports 2DPC
- Security Features
 - CXL Link-Level Integrity and Encryption (IDE)
 - AES-256 Encrypted DDR Memory Interface
 - Firmware Authentication, Integrity Check
- RAS Features
 - Single Error Correction and Double Error Detection
 - Advance EDC
 - Memory Mirroring
 - Rank Sparring
- - Scrubbing
 - On-Demand Memory Migration
 - Temperature Monitoring and DRAM Throttling
 - Fault Isolation, Error logging and Reporting
- Advanced Analytics
 - Write and Read Latency Monitoring
 - CXL Quality of Service (QoS) Telemetry
 - Transaction Counter and logs
- Post-Package Repair (PPR) and on-die Error Check and Scrub (ECS)
- Auxiliary power connection
 - Power envelope exceeds 75W so an aux 12V power connection is needed
- Memory Expansion Applications
 - Accelerated AI and ML Workloads
 - Large In-memory databases
 - Banking, Finance, OLTP
 - Tiered cache for general purpose storage

System Block Diagram

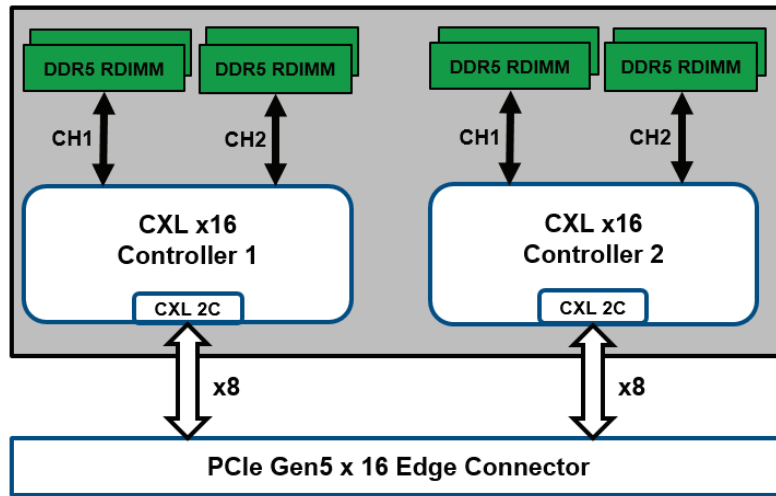

Dimensions

The 8-slot AIC uses Full Height Half Length PCIe form factor.

- Height: 111.15mm
- Length: 167.52mm
- Width: 39.17mm

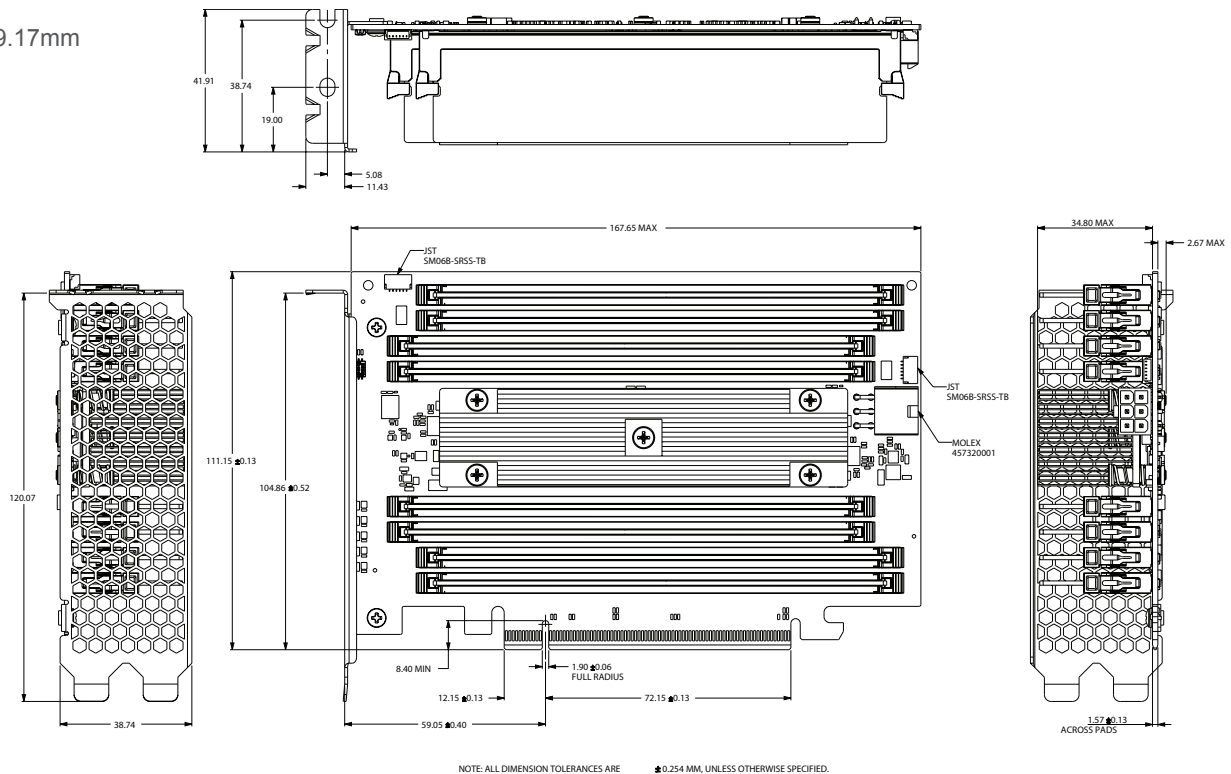

The AIC uses a standard 12V PCIe 6-pin RA through hole aux power connector. This connector will support standard ATX Power Supply cables.

PCI Express 2x3 Auxiliary Power Connector Definition

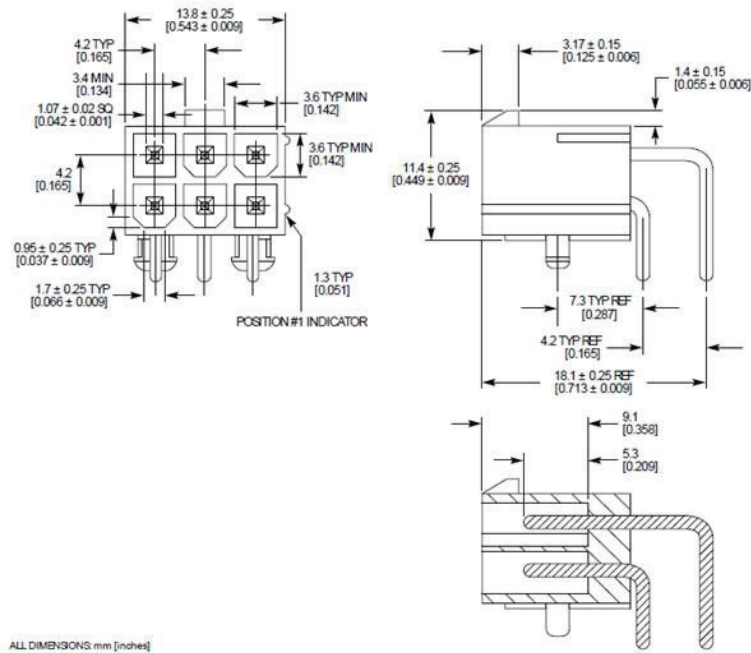

Ordering Information

8-Socket AIC		
SMART Part Number	Description	Configuration
STXPLXXGAA8RD5	CXL, PCIe x16, DDR5, AIC FHHL	Card PN without RDIMM
STXPL256GAA8RD5	CXL, PCIe x16, 256GB, DDR5, FHHL	Card PN with 8 of 32GB RDIMM
STXPL512GAA8RD5	CXL, PCIe x16, 512GB, DDR5, FHHL	Card PN with 8 of 64GB RDIMM
STXPL001TAA8RD5	CXL, PCIe x16, 1TB, DDR5, FHHL	Card PN with 8 of 128GB RDIMM

Contact: Torry Steed at torry.steed@smartm.com for any sales and sampling queries.



For more information, please visit: www.smartm.com

*Product images are for promotional purposes only. Labels may not be representative of the actual product.

Headquarters/North America:

T: (+1) 800-956-7627 • T: (+1) 510-623-1231

F: (+1) 510-623-1434 • E: info@smartm.com

Latin America:

T: (+55) 11 4417-7200 • E: sales.br@smartm.com

Asia/Pacific:

T: (+65) 6678-7670 • E: sales.asia@smartm.com

EMEA:

T: (+44) 0 7826-064-745 • E: sales.euro@smartm.com

Customer Service:

T: (+1) 510-623-1231 • E: customers@smartm.com